

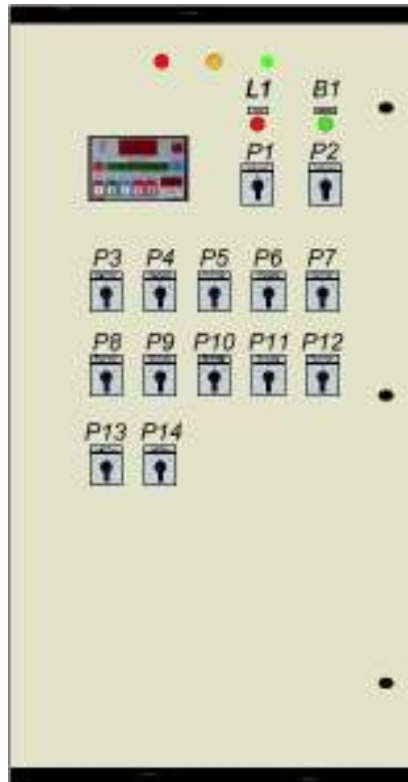

Series VKS CHICKBOOK On-Off Fan Control Panels User's Guide



INDEX	PAGE
SAFETY PRECAUTIONS AND WARNINGS	3
1.General Informations	3
1.1. Technical Spesifications	4
1.2. General Panel Appearance	5
1.3. Equipment Descriptions	5
2. Installation and Start-Up	12
2.1. Start-Up Controls	12
2.2. Installation	12
2.3. Cable connections of motors and field equipments	13
2.4. Energizing and first setup	13
3. Processor Usage and Programming	13
4. Periodic Maintanance	23
5. Suggestions	24
6. Fault Detecion and Trouble Shooting	25

SAFETY PRECAUTIONS AND WARNINGS

WARNING

Before installation and energizing of fan control panel, please read safety precautions and warnings carefully!

- Imbalances in your electricity network (low and high voltages) might destroy the panel and stop it to work properly.
- There is high voltage electricity energy which can be dangerous for human health and the equipments. Interference to the panel or equipments connected to the panel without cutting out the energy might result serious damages for human health or equipments.
- Usage of the panel for long years depends on installing properly, operating and having periodic maintenance by authorised personnel.

ATTENTION

- Please inhibit unauthorised people especially children to reach and interference the panel.
- Please do not forget that all electrical equipments can cause fire. Because of this place the panel away from high temperature, fire and liquids. Do not put easy to fire materials near the panel like nylon, wood or chemicals.
- This panel can be used only with the equipments that are specified by VKS. Changes made without prior notice and approval of VKS might cause serious damages.
- Please place this user's guide at an easy to reach place for all operators who might be have to operate the panel.

1. GENERAL INFORMATIONS

This fan control panel that you have bought has been developed by long years of experience of VKS in the sector and by using all technologic improvements.

Poultry fan control panel is a control panel which is designed to provide the fresh air needed inside the house. It is possible to feed more bird in the

equiped houses than natural ventilated houses per square meter area. In summer, when the temperature inside the house increases, the fans start to work and make fresh air fill inside house by passing through ped panels and cool the house. The temperature is reduced to the desired value by this method. In winter the fans make fresh air come inside the house just to breathe fort he animals not to reduce the temperature. When the fans stops the shutters close and heating energy loss is minimised.

The microcomputer on the front cover of the panel is called VKS CHICKBOOK. VKS CHICKBOOK microcomputer makes the fans work according the house needs automatically.

In automatic mode number of working fans is determined by the microcomputer according the house needs and the parameters which will be adjusted by the operator.

When the panel is made to work in hand mode; the speed and number of working fans is controlled by the operator. In this mode the fans will work or will not work according to the comands of operator.

1.1. Technical Specifications

Supply Voltage : 3 Phase, Neutrol line and self grounded network.

Working Voltage : Between Phases 360...400 V AC.
Between Phase and Neutral 200...240 V AC.

Power Consumption : Varies according to the panel type. The total power of equipments that can be connected to the panel is equal to the power of panel.

Fan Control Type: 10 steps on-off control by direct feeding voltage.

Panel Dimensions : Varies according to the panel type.

1.2. Panel General Appearance

PANEL INSIDE APPEARANCE FRONT PANEL APPEARANCE

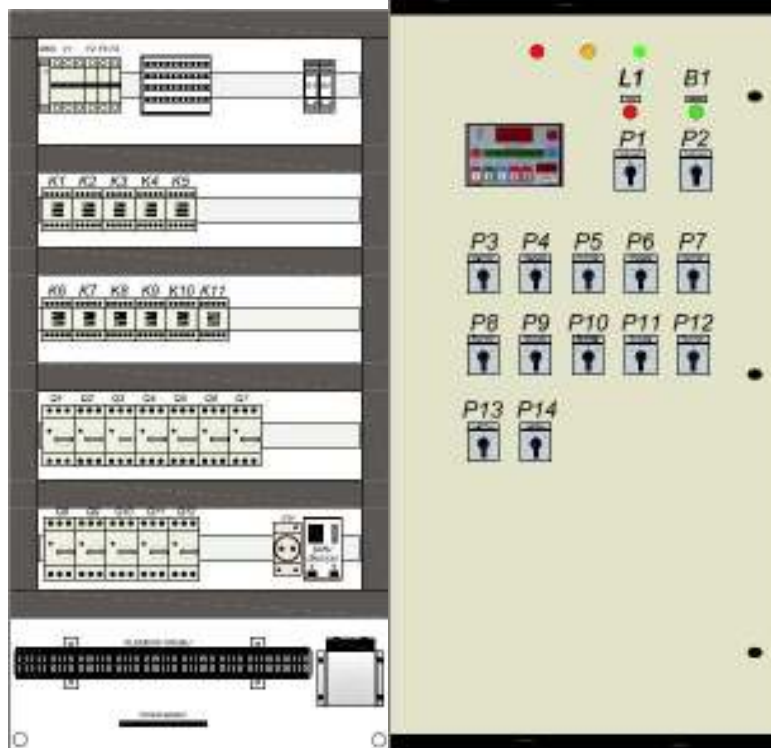

1.3. Equipment Definitions

Front appearance. Front panel equipments:

VKS CHICKBOOK Microcomputer (poultry computer).

Heaters (radian), cooling panels, pumps, fans and alarms are controlled by this equipment. The user or operator loads parameters to the controller as described in section 3. Controller keeps the parameters when electricity goes off too.

- P1** 0 – 1 (off-on) positioned, main alarm switch.
In alarm situations this switch is used to silence the horn until removing the alarm situation. In normal working conditions this switch should never be closed and should always be on 1 position.
- P2** 0 – 1 positioned Thermic alarm switch, motor protection relays alarm silencing switch.
Used to silence the alarm when a thermic fault or short circuit occurs at one of the motors in all group.

WARNING

Never forget to take P1 Switch to 1 position to be able to hear the after coming alarms.

- P3** 1 – 0 – 2 positioned, 1 numbered tunnel fan group hand-0-automatic selection switch.
1 position of switch makes the connected fan group work independent from the controller and named as hand mode.
0 position of switch makes the connected fan group stop working. The fan group does not work if the computer tries to make it work too.
2 position of switch makes the connected fan group work according to the controller and named as automatic mode.
- P4** 1 – 0 – 2 positioned, 2 numbered tunnel fan group hand-0-automatic selection switch.
1 position of switch makes the connected fan group work independent from the controller and named as hand mode.
0 position of switch makes the connected fan group stop working. The fan group does not work if the computer tries to make it work too.
2 position of switch makes the connected fan group work according to the controller and named as automatic mode.
- P5** 1 – 0 – 2 positioned, 3 numbered tunnel fan group hand-0-automatic selection switch.
1 position of switch makes the connected fan group work independent from the controller and named as hand mode.

0 position of switch makes the connected fan group stop working. The fan group does not work if the computer tries to make it work too.

2 position of switch makes the connected fan group work according to the controller and named as automatic mode.

P6 1 – 0 – 2 positioned, 4 numbered tunnel fan group hand-0-automatic selection switch.

1 position of switch makes the connected fan group work independent from the controller and named as hand mode.

0 position of switch makes the connected fan group stop working. The fan group does not work if the computer tries to make it work too.

2 position of switch makes the connected fan group work according to the controller and named as automatic mode.

P7 1 – 0 – 2 positioned, 5 numbered tunnel fan group hand-0-automatic selection switch.

1 position of switch makes the connected fan group work independent from the controller and named as hand mode.

0 position of switch makes the connected fan group stop working. The fan group does not work if the computer tries to make it work too.

2 position of switch makes the connected fan group work according to the controller and named as automatic mode.

P8 1 – 0 – 2 positioned, 6 numbered tunnel fan group hand-0-automatic selection switch.

1 position of switch makes the connected fan group work independent from the controller and named as hand mode.

0 position of switch makes the connected fan group stop working. The fan group does not work if the computer tries to make it work too.

2 position of switch makes the connected fan group work according to the controller and named as automatic mode.

P9 1 – 0 – 2 positioned, 7 numbered tunnel fan group hand-0-automatic selection switch.

1 position of switch makes the connected fan group work independent from the controller and named as hand mode.

0 position of switch makes the connected fan group stop working. The fan group does not work if the computer tries to make it work too.

2 position of switch makes the connected fan group work according to the controller and named as automatic mode.

P10 1 – 0 – 2 positioned, 8 numbered tunnel fan group hand-0-automatic selection switch.

1 position of switch makes the connected fan group work independent from the controller and named as hand mode.

0 position of switch makes the connected fan group stop working. The fan group does not work if the computer tries to make it work too.

2 position of switch makes the connected fan group work according to the controller and named as automatic mode.

P11 1 – 0 – 2 positioned, 9 numbered tunnel fan group hand-0-automatic selection switch.

1 position of switch makes the connected fan group work independent from the controller and named as hand mode.

0 position of switch makes the connected fan group stop working. The fan group does not work if the computer tries to make it work too.

2 position of switch makes the connected fan group work according to the controller and named as automatic mode.

P12 1 – 0 – 2 positioned, 10 numbered tunnel fan group hand-0-automatic selection switch.

1 position of switch makes the connected fan group work independent from the controller and named as hand mode.

0 position of switch makes the connected fan group stop working. The fan group does not work if the computer tries to make it work too.

2 position of switch makes the connected fan group work according to the controller and named as automatic mode.

P13 1 – 0 – 2 positioned, pump group hand-0-automatic selection switch.

1 position of switch makes the connected pump group work independent from the controller and named as hand mode.

0 position of switch makes the connected pump group stop working. The pump group does not work if the computer tries to make it work too.

2 position of switch makes the connected pump group work according to the controller and named as automatic mode.

WARNING

P13 After making the pump group work in hand mode by making putting the switch 1 position should be again taken in to 2 position. Unless this is not done, the pump group goes on working and makes the temperature inside the house go down.

P14 1 – 0 – 2 positioned, heater group hand-0-automatic selection switch.

1 position of switch makes the connected heater group work independent from the controller and named as hand mode.

0 position of switch makes the connected heater group stop working. The heater group does not work if the computer tries to make it work too.

2 position of switch makes the connected heater group work according to the controller and named as automatic mode.

L1-2-3 Panel input power phase lamps. They are helpfull in observation of phase failures.

L4 Alarm lamp.

It is a visual caution in alarm situations. It goes on working if the P7 alarm switch is closed too. It is so important in observation of alarm situations in case of horn failure or cable failure of horn.

B1 Horn test buton. It is used to test the horn if it is working or not in normal conditions.

Interior Appearance. Equipments of assembly plate:

CHARGE UNIT

Battery charge unit.

It is used to charge the batteries that are very important fort he continuity of alarms cautions in case of power failure.

- K1, ...K10** Fan motors step contacters.
Supplies the energy needed for fan motor groups to work.
- K11** Pump motor contacter.
Supplies the energy needed for pump group.
- Q1, ... Q10** Thermic magnetic protection relay for fan motors.
Protects fan motors against phase failure and over load current. Additionally these relays protect the panel against short circuits in field. Motors can be switched on or closed by the red or black buttons on relays.
- Q11, Q12** Thermic magnetic protection relay for fan pump motors.
Protects pump motors against phase failure and over load current. Additionally these relays protect the panel against short circuits in field. Motors can be switched on or closed by the red or black buttons on relays.

WARNING

Do not switch on any one of motors by the black button on the motor protection relays when the panel is energized. To switch on a motor, first of all switch off the energy of whole panel.

- A1, A2** Batteries
There are two batteries connected in series. Each of them has a capacity of 4 Ah and voltage of 6 V. The batteries are held under buffer charge. In any case of alarm situation the horn works through battery energy.
- MKS03** Phase protection relay
Protects the panel and motors connected to the panel against failures in the energy feeding network. Failure of any one of the phases, wrong phase sequence, neutral failure or %20 voltage drop in one phase against other phases are possible reasons for phase protection relay to stop the whole panel working. If there occurs any one of these causes, MK03 stops panel working and provides an alarm output for energy feeding problems.

- F1** Panel input fuse
Protects panel against short circuits inside the panel. In case of a short circuit inside panel, this fuse cuts off the energy and protects the panel.
- F2** Remote fuse
Energy needed for all remote equipments inside panel (VKS CHICKBOOK, radiators, stove and charge unit) is provided by this fuse. If there occurs a fault in one of these equipments, this fuse cuts off energy and protects the panel.
- F3, F4** Radiator and stove fuse
These fuses are signal and energy fuses for heater equipments.

NOTE

When remote fuse is closed;
VKS CHICKBOOK, radiator, stove and charge unit stay out of energy.
Unless this fuse is opened none of these equipments work.

- R1** Alarm control relay
In alarm situations this relay makes the alarm lamp and horn work. In case of alarm system faults this relay should be checked.
- R2** Heater control relay
Controls the heater equipments. When heater system is activated by VKS CHICKBOOK or operator this relay is energized and provides a 220 V output for radiators and a free contact for stove. This relay should be checked in case of heater equipment failure.

2. INSTALLATION and START-UP

In this section, installing the panel to its place, connection of equipment cables, energizing and steady state adjustments will be explained.

2.1. Start-Up Controls

When you open the original package of panel please check that you completely got all the equipments below which are supplied with panel in standard option. The equipments listed below should be supplied with panel:

- Horn, 1 piece
- Inside temperature sensor, 1 piece
- Outside temperature sensor, 1 piece
- Humidity sensor, 1 piece
- Joining apparatus for wall mounting, 4 pieces
- Panel cover key, 1 piece
- Terminal box connection scheme.
- Type code labeled on out of panel cover
- Series number and production date labeled inside of front cover.
- Battery warning and green test approval labeled on assembly plate inside panel.

2.2. Installation

WARNING

Choosing right place for installation, wall mounting, cable choosing and cable connections are very important because these Works will be done only once and directly affects life of panel and equipments.

Panel should be placed in a closed, air conditioned and especially away from dust. Sun rays should not reach panel surface directly and unauthorized people should not be able to reach the panel. Panel should not be mounted on outer wall of poultry house and it should not be covered with nylon or something like this. All cables coming to the panel should enter panel through cable entrance hole which is placed under the panel.

2.3. Connecting motor and equipment cables

First think to do is connecting 3 phase 380 V AC network to panel's L1, L2 and L3 terminals as shown in terminal box diagram. Neutral line of network should be connected to terminal named as N. Besides these panel should be grounded with a separate ground line for protection of panel against electrical faults. All cables coming from equipments inside house should be connected to panel as shown in terminal box diagram properly for acceptable conductivity.

2.4. Energising and First Set-Up

After all electrical connections, panel is energised by opening the F1 and F2 named fuses. For start-up all thermic magnetic switches are closed as off position and all switches are set to 1 position for hand mode. All thermic magnetic switches are set to on position for running all motors one by one. By this way all motors and their direction of turn should be checked. If there is determined any motor with an opposite direction of turn, 2 of 3 cables of related motor should be changed to correct direction.

3. PROCESSOR USAGE AND PROGRAMMING

3.1.1 Technical Specifications

Circuit system Electricity pressure	220 (+/-10%)	VAC
Frequency	50-60	Hz
Electric power	9	VA
Fireproofing rate for relay	250VAC, 3A	
Temperature for using	-20 - 60	°C
Measurement range temperature	-10.0 – 70.0	°C
Accurate value	0.1	°C
Deviation value	+/-1	%
Measurement range Humidity	0.0 – 99.9	%RH
Accurate value	0.1	%
Deviation value	+/-5	%

3.2.1 Analog Input Connections

1. Temperature sensors

T1 is used for indoor temperature sensor. Use a two wire cable. Connect one wire to analog input T1 and second wire to the 0V input.

T2 is used for outdoor temperature sensor. Use a two wire cable. Connect one wire to analog input T2 and second wire to the 0V input.

2. Humidity sensor

HUM is used for indoor humidity sensor. Use a three wire cable. Brown to input 12V, Green to 0V and White to HUM.

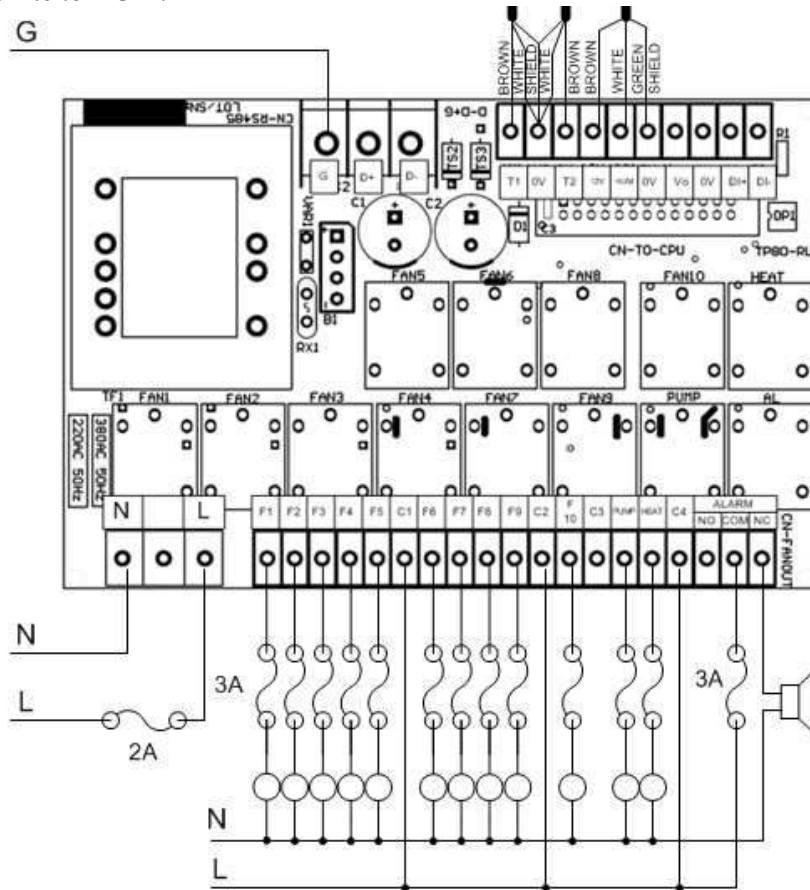

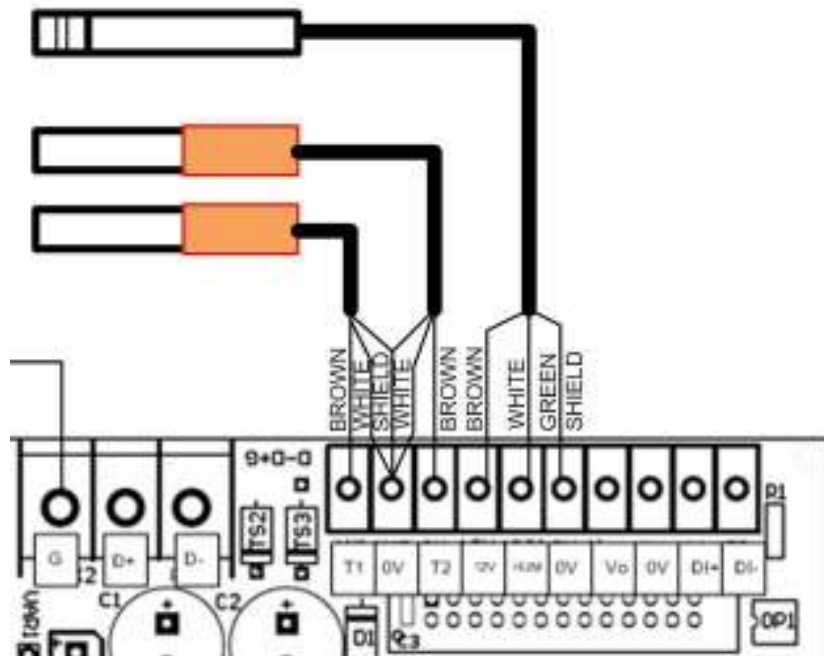

3.2.2 Relay Connections

Connect the relay outputs to the various systems. All outputs are dry contact, maximum 3A/250VAC

Relay list

SYMBOL Output

F1 Fan group 1

F2 Fan group 2

F3 Fan group 3

F4 Fan group 4

F5 Fan group 5

F6 Fan group 6

F7 Fan group 7

F8 Fan group 8

F9 Fan group 9

F10 Fan group 10

PUMP Cooling pump

HEAT Heater

ALARM Alarm

3.2.3 Analog Output Connection

Vo is used for the variable speed fan (inverter).

3.2.4 Digital Input Alarm

DI is used for the external alarm signal. Connect 24VDC to DI+ and the seconds 0VDC to DI-. When the signal from the external alarm, the dry contact alarm will be in normally close state.

3.3 OPERATION

The VKS CHICKBOOK will display the temperature and humidity inside the house. The representation will be alternately displayed. If that is not the humidity sensor. System will not show the humidity. Displays the temperature inside the house alone.

The VKS CHICKBOOK will display the operation of the relay and the fan speed.

Turn on power

Each time power is connected to the unit “1.0U” will appear on the display. This number is version number, and is unique for this program version.

3.3.1 Change of Display

Push on button. For select the display.

1. T_1 This is a reading of the current indoor temperature.
2. T_2 This is a reading of the current outdoor temperature.
3. HvM This is a reading of the current indoor temperature.
4. ALM Notification error (If no errors. Do not show this message.)
 - HAL Error greater than or equal to the temperature specified.
 - LAL Error less than or equal to the temperature specified.
 - HHV Error greater than or equal to the humidity specified.
 - DiN Error from digital input alarm.

3.3.2 Change of Set Point

It is possible to change each set point.

1. Push on button. For select the function.
2. Push on button. For increase the data. Or push on button. For reduce the data.

When editing data values. Will be flashing.

3. Check the display to see if the information is correct. If yes, Push on button.
4. Push on function button to change function. Or exit from the set point function

3.3.3 Set Points Functions

Heater (HEAT)

- **heat**

Enter here the temperature at heater turned off. The temperature at the turn on heater is calculated form the value of heat minus the value of dhEt. As set heat at 25.0°C and dhEt were 1.0 heater to turn off at 25.0°C and will turn on again. Temperature is less then or equal to 24.0°C. (Factory-set value dhEt were 1.0°C, Users can edit it.)

Ventilation (VENT)

- **F01**

Enter here the temperature at fan1 will be turned on. The temperature at the turn off fan1 is calculated form the value of F01 minus the value of dFAN. As set F01 at 21.0°C and dfan were 1.0 fan1 to turn on at 21.0°C and turn off. Temperature is less then or equal to 20.0°C. (Factory-set value dfan were 1.0°C, Users can edit it.)

- **F02**

Enter here the temperature at fan2 will be turned on.

- **F03**

Enter here the temperature at fan3 will be turned on.

- **F04**

Enter here the temperature at fan4 will be turned on.

- **F05**

Enter here the temperature at fan5 will be turned on.

- **F06**

Enter here the temperature at fan6 will be turned on.

- **F07**

Enter here the temperature at fan7 will be turned on.

- **F08**

Enter here the temperature at fan8 will be turned on.

- **F09**

Enter here the temperature at fan9 will be turned on.

- **F10**

Enter here the temperature at fan10 will be turned on.

- **Fon**

Enter here the time period in minutes and seconds (x10) that the fan1 will run once the house temperature has below the fan1 temperature (Function “F01”). The fan1 will run in an on-off cycle.

- **Fof**

Enter here the time period in minutes and seconds (x10) that the fan1 will be off during the fan1 cycle.

Note: Enter “0.0” to disable this function.

- **SPFL**

Enter here the minimum speed set in percentage that the variable speed fan will run.

- **SPFH**

Enter here the maximum speed set in percentage that the variable speed fan will run.

- **T_Lo**

Enter here the minimum temperature setting to control the fan speed minimum.

- **T_Hi**

Enter here the maximum temperature setting to control the fan speed maximum.

Example:

SPFL = 30 %

SPFH = 100 %

T_LO = 23.0°C

T_Hi = 30.0°C

As long as the indoor temperature is below 23.0°C the variable speed fan will be running at 30%. When the temperature reaches 23.0°C the variable speed fan will start to increase in speed. By the time the house temperature has reached 30.0°C variable speed fan will be running at 100%.

Cooling Pump (COOL)

- **CP**

Enter here the temperature at pump will be turned on. The temperature at the turn off pump is calculated from the value of CP minus the value of dCP. As set CP at 27.0°C and dCP were 1.0 pump to turn on at 27.0°C and turn off. Temperature is less than or equal to 26.0°C. (Factory-set value dCP were 1.0°C, Users can edit it.)

- **HvCP**

Enter here the humidity at pump turned off. The humidity at the turn on pump is calculated from the value of HvCP minus the value of dhVM. As set HvCP at 80.0% and dhVM were 2.0 pump to turn off at 80.0% and will turn on again. Humidity is less than or equal to 78.0%. (Factory-set value dhVM were 2.0%, Users can edit it.)

- **CPon**

Enter here the time period in minutes and seconds (x10). The pump will run in an on-off cycle.

- **CPof**

Enter here the time period in minutes and seconds (x10) that the pump will be off during the pump cycle.

Note: Enter "0.0" to disable this function

- **TE-2**

Enter here the outdoor temperature for the reduction of timer off pump by dividing the value Cpod divide two such set at 32.0°C and Cpod was 60.0 when the outdoor temperature is higher than or equal to 32.0°C. Time to off the pump will be changed from 60 minutes to 30 minutes. (If you want to disable the set 99.9°C)

- **TE-4**

Enter here the outdoor temperature for the reduction of timer off pump by dividing the value Cpod divide four such set at 37.0°C and Cpod was 60.0 when the outdoor temperature is higher than or equal to 37.0°C. Time to off the pump will be changed from 60 minutes to 15 minutes. (If you want to disable the set 99.9°C)

Note:

- If there is no humidity sensor. System will not be used in the humidity control function HvCP will disable.
- If there is no outdoor temperature sensor. System will not be used in temperature control function TE-2 and TE-4 will disable.
- Pump will turn on. When the indoor temperature greater than or equal to the value set in the CP and then to check the humidity from the value set in HuCP if conditions right It will turn on pump at the set value from function 3.3 to 3.6.

3.4 Alarm (ALARM)

- **HAL**

Enter here the maximum temperature required notification. In case of the controller will activate the alarm relay and high temperature alarm status will activate.

- **LAL**

Enter here the minimum temperature required notification. In case of the controller will activate the alarm relay and low temperature alarm status will activate.

- **HvAL**

Enter here the maximum humidity required notification. In case of the controller will activate the alarm relay and high humidity alarm status will activate.

- **ALon**

Enter here the time period in seconds. The alarm relay will run in an on-off cycle.

- **ALof**

Enter here the time period in seconds that the alarm relay will be off during the alarm cycle.

Note:

- Enter "0.0" to disable this function
- When the controller will activate the alarm relay. If any button is pressed. Alarm relay will delay for 15 minutes.

3.5 Setup Controller (SETUP)

Mode users

- **bFC**

Increase the speed fan mode, the variable fan speed (inverter) for ventilation.

- **___** Will run by the time of bFon and bFof.
- **THH** Will run when the temperature is higher than or equal to T_{BF}, or humidity higher than or equal to HvCP.
- **TLH** Will run when the temperature is less than or equal to T_{BF} minus 0.5°C, or humidity higher than or equal to HvCP.
- **H** Will run when the humidity is higher than or equal to HvCP.
- **TH** Will run when the temperature is higher than or equal to T_{BF}.
- **TL** Will run when the temperature is less than or equal to T_{BF} minus 0.5°C.

- **t_bf**

Enter the temperature increase the fan speed mode. If a set bFC THH, TLH, TH, TL

- **bf**

Enter the fan speed to increase as the mean of 20% controller speed up to 20% of normal when conditions. **5.4** bFon

Enter here the time period in minutes and seconds (x10). The increase the speed fan mode will run in an on-off cycle.

- **bfof**

Enter here the time period in minutes and seconds (x10) that the increase the speed fan mode will be off during the cycle.

Note: Enter “0.0” to disable this function

- **HHon**

Enter here the time period in minutes and seconds (x10) that the cooling pump system will run once the indoor temperature has reached the required temperature for cooling pump and indoor humidity rises above required humidity. The cooling pump will run in an on-off cycle.

- **HHof**

Enter here the time period in minute and seconds (x10) that the cooling pump will be off during the cooling pump high humidity cycle.

Note: Enter “0.0” to disable this function

- **dPM**

Open or hidden mode technicians. (Specific technical information of the only)

0 = Open mode technicians

1 = Hidden mode technicians

mode technicians

- **Hn**

It is possible to connect the unit to a PC computer with the help of the “TEMPVIEW” software package. It is possible to manage up 99 units. Each controller needs a house number.

- **DLY**

Delay the operation of the controller set start time from 3 to 180 seconds.

- **F10**

Select the relay function of Fan10

0 = normally open (NO)

1 = normally close (NC)

- **dhet**

Enter here the number of degrees below the heater temperature that heater will be turn on.

- **dFan**

Enter here the number of degrees below the fan temperature that fan will be turn off.

- **dCP**

Enter here the number of degrees below the cooling pump temperature that cooling pump will be turn off.

- **dHvm**

Enter here the number of percentage below the humidity for cooling pump that cooling pump will be turn on.

- **t_1**

This is reading of the current indoor temperature. It is possible here to adjust the temperature reading.

- **t_2**

This is reading of the current outdoor temperature. It is possible here to adjust the temperature reading.

- **HvM**

This is reading of the current indoor humidity. It is possible here to adjust the humidity reading.

- **rset**

This is function for reset controller. To be used by technicians.

- 1 = Load User Parameter
- 2 = Clear Adjust Sensor
- 5 = Load Factory Parameter
- 8 = Save User Parameter

- **trL**

This is function for test relay. To be used by technicians.

- **tspf**

This is function for test variable speed fan. To be used by technicians.

- **t7dp**

This is function for test 7 segments. To be used by technicians..

4. PERIODIC MAINTANANCE

Fan control panel does not need a heavy maintainance. In busy working conditions it's working should be checked. The alarm system should be checked frequently. It should be cleaned from dust and powders between growth sessions. The biggest problem for control panels in usage is dust. If the panel is wanted to be used for long years, it's periodic maintainance should be done. Just because of this dust and powder cleaning is very important for control panels.

Between growth sessions the battery cables should be disconnected to disable alarms and make the batteries long life.

The alarm system should be checked frequently by testing thermic magnetic switches and VKS CHICKBOOK temperature alarms. It is always very important to keep the alarm system working.

The equipments used inside panel has an end of mechanical and electrical life like everything on earth. Their failure by the time is a normal result. Making the panel and equipment's using life longer depends on installation place choice, electrical network conditions, periodic maintainance, humidity and other environmental conditions. The most important factor for contactor's life is dust. Because of this panel periodic maintainance should be done frequently.

It's adviced to change all contacter switchs with new ones once in 2 or 3 years. It should bdone not to live a fault with panel when there is animal inside house. Possible contacter faults will be seen probably at the first step contacters by time. When there is animal inside, for not to fall in trouble with a contacter fault, it is adviced to keep spare 1 or 2 contacters near panel.

5. SUGGESTIONS

WARNING

This section is prepared to make your panel life longer and work properly. All suggestions are adviced because of experiences.

- You should not connect motor or equipment more than the capacity of panel. No more equipment should not be energised through panel accept the ones explained in technical spesifications of panel.
- If the distance between the panel and fan motors with power of 1.1 kw, the connection cable should be choosen with dimensions of 4x2.5 mm.
- All fan motors should be grounded locally.
- Front cover of panel should always be closed.
- Between two animal growth term, the panel should be cleaned with vacuum cleaner. Panel should never be cleaned with water or any liquid else.
- No cable or connection inside the panel should be changed.
- You should use a power generator against power failures.
- In case of power failures, the power generator should be tested against fan directions.
- The cable canals inside panel should always be kept closed.
- If there is a telephone near the panel, it will be easier to solve the problems that can ocur in future.

- It will protect the animals against death because of closeness if you have natural ventilating system in case of panel failures.
- The horn should be placed at a place that everybody interested in safety of animals inside can hear it.
- The inside temperature sensor should be placed just in to the midpoint of house. It should be placed as near as possible to floor but as high as the animals can not damage the sensor.
- During cleanup between growth terms, the energy of panel should be cut and panel should be closed with a cover like nylon or something like this to protect the panel against water and disinfectant vapour.
- In electric circuit of panel, there should not be made any addition or subtraction.
- Panel should never be used without its aim.

6. FAULT DETECTION AND TROUBLE SHOOTING

This section is prepared to help user in case of possible faults. It is aimed to solve possible problems as quick as possible by the operator.

FAULT DETECTION AND TROUBLE SHOOTING		
Energy connections are made but stil the panel is not energised.		
POSSIBLE REASON	FAULT DETECTION	SOLUTION
There may not be enery in connection cables.	Please control network volrages. (Between phases 360...400 V AC) (Between phase neutral 200...240 V AC)	If the problem occurs because of network voltages, the problem must be solved by energy supplier.
Phase sequence might be wrong.	Control the light on MKS03 that if it is on or off.	If the light is off, change the phase sequence until the light comes on position.
The voltages might be low.	Please control network volrages. (Between phases 360...400 V AC) (Between phase neutral 200...240 V AC)	If the problem occurs because of network voltages, the problem must be solved by energy supplier.
One or some of network voltages might be off.	Please control network volrages. (Between phases 360...400 V AC) (Between phase neutral 200...240 V AC)	If the problem occurs because of network voltages, the problem must be solved by energy supplier.
MKS03 might be broken.	Control the light on MKS03 that if it is on or off.	If the light is on, change the MKS03 with a new one.Eğer ışık yamıyorsa MKS03'ü yenisi ile değiştirin. NOTE: Do not change the sequence of cables connected to MKS03 when changing MKS03.
F1 And F2 fuses might be off.	Control F1 and F2 fuses.	If the fuses are off, turn on them and energise the panel.

VKS CHICKBOOK is working out of parameters installed in it.		
POSSIBLE REASON	FAULT DETECTION	SOLUTION
VKS CHICKBOOK parameters might be entered different.	Check the parameter values.	Correct the parameter values. If you couldn't detect the wrong parameter make your VKS CHOCKBOOK turn back to factory settings.

VKS CHICKBOOK is working out of parameters installed in it. (When the VKS CHICKBOOK is made to turn back to factory settings.).		
POSSIBLE REASON	FAULT DETECTION	SOLUTION
VKS CHICKBOOK might be broken.	Check if you made the VKS CHICKBOOK turn back to factory settings correctly.	If you are sure that you have made the VKS CHICKBOOK turn back to factory settings correctly and stil it is not working, please contact to your seller.

Faults occuring time to time.

POSSIBLE REASON	FAULT DETECTION	SOLUTION
Equipment screws, terminal box screws or sockets of equipments might be loosen.	Check all the screws inside panel, on equipments and the sockets.	If the fault is occuring because of this reason, tihten all screws and solve the problem.

VKS CHICKBOOK is working but fans are not working.		
POSSIBLE REASON	FAULT DETECTION	SOLUTION
Thermic magnetic protection relay might be off.	Check the butons on the thermic magnetic protection relay if they are open or closed.	If the buttons are closed turn on them and solve the problem.
The temperature set value that VKS CHICKBOOK will start fans working might be set too high.	Control the temperature set value.	If it is set too high, solve problem by correcting the temperature set value.

Switches that control working type of fan groups might be closed.	Control the switches.	If the switches are closed, change them to (2) automatic working condition.
---	-----------------------	---

Fan thermic magnetic switches goes off.		
POSSIBLE REASON	FAULT DETECTION	SOLUTION
The temperature at the room that the panel works in might be too high.	Check the room temperature.	If the problem occurs because of high temperature, cool the room and solve problem.
Panel might be placed under direct sun light.	Check the panel placement.	If the panel is placed under direct sun light, embrass the sunlight.
Contacters might be broken.	Check the contacters.	Change the broken contacters with the new ones.

Fan thermic magnetic switches goes off consecutively.		
POSSIBLE REASON	FAULT DETECTION	SOLUTION
Current set of thermic magnetic switch might be set too low for related motor.	Check the current set of thermic magnetic switch.	If the current is set too low, increase it up to the value that is declared on the lable of related motor.
Motor might be broken.	Check the related motor.	If the motor is broken change it with a new one.
Cable that connects the motor to the panel might be broken.	Check the related cable.	If the cable is broken, change it with a new one.

Fansa re working in hand mode but they are not working in automatic mode.		
POSSIBLE REASON	FAULT DETECTION	SOLUTION
The voltages might be low.	Please control network voltages. (Between phases 360...400 V AC) (Between phase neutral 200...240 V AC)	If the problem occurs because of network voltages, the problem must be solved by energy supplier.
Phase sequence might be wrong.	Control the light on MKS03 that if it is on or off.	If the light is off, change the phase sequence until the light comes on position.
MKS03 might be broken.	Control the light on MKS03 that if it is on or off.	If the light is on, change the MKS03 with a new one.Eğer ışık yamıyorsa MKS03'ü yenisi ile değiştirin. NOTE: Do not change the sequence of cables connected to MKS03 when changing MKS03.

Radians are not working.		
POSSIBLE REASON	FAULT DETECTION	SOLUTION
Radian working temperature set value might be set to a very high or low value.	Check the radian working temperature set value.	If the problem occurs because of radian working temperature set value, correct it and solve the problem.
The radian relay on VKS CHICKBOOK might be broken.	Check the relay.	If the relay on VKS CHICKBOOK is broken, please refer to your seller.

The terminal box or the cable connected to radian valve might be broken.	Check the terminal box and cable.	If there is a problem with terminal box, solve it by tightening the screw on terminal. If the cable is broken change it with a new one.
Gas valve might be broken.	Check the valve. NOTE: When you energise the valve from panel, the valve must make a noise if it is working. You can check the valve by this way.	If the gas valve is broken change it with a new one.

Radians are working continuously.

POSSIBLE REASON	FAULT DETECTION	SOLUTION
Radian working temperature set value might be set to a very high or low value.	Check the radian working temperature set value.	If the problem occurs because of radian working temperature set value, correct it and solve the problem.
The radian relay on VKS CHICKBOOK might be broken.	Check the relay.	If the relay on VKS CHICKBOOK is broken, please refer to your seller.

Pump motors are not working.

POSSIBLE REASON	FAULT DETECTION	SOLUTION
Pump working temperature set value might be set to a very high value.	Check the pump working temperature set value.	If the pump working temperature set value is set to a very high value, solve the problem by correcting it.
P12 switch might be at (0) position.	Control the position of P12 switch.	If P12 switch is at (0) position, solve the problem by taking it to (1) or (2) position.
P12 switch might be broken.	Check the P12 switch.	If P12 switch is broken, change it with a new one.

Pump thermic magnetic protection switch might be off.	Check the pump thermic magnetic protection switch.	If pump thermic magnetic protection switch is at off position, take it to on position.
Pump contactor switch might be broken.	Check the pump contactor switch.	If it is broken, change it with a new one.
The pump relay on VKS CHICKBOOK might be broken.	Check the relay.	If the relay on VKS CHICKBOOK is broken, please refer to your seller.

Pumps are working continuously.

POSSIBLE REASON	FAULT DETECTION	SOLUTION
Pump working temperature set value might be set to a very low value.	Check the pump working temperature value.	If pump working temperature set value is set to a very low value, solve the problem by correcting pump working temperature set value.
The pump relay on VKS CHICKBOOK might be broken.	Check the relay.	If the relay on VKS CHICKBOOK is broken, please refer to your seller.
P13 switch might be at (1) position.	Check the P12 switch position.	If the switch is at (1) position, solve the problem by taking the switch to (0) or (2) position.
Pump contactor switch might be broken.	Check the pump contactor switch.	If it is broken, change it with a new one.
Pump thermic magnetic protection switch might be broken.	Check the pump thermic magnetic switch.	If it is broken, change it with a new one.

Pump motor thermic magnetic protection switch is going off. (Stops the motor)

POSSIBLE REASON	FAULT DETECTION	SOLUTION
The temperature at the room that the panel works in might be too high.	Check the room temperature.	If the problem occurs because of high temperature, cool the room and solve problem.

Pump contactor switch might be broken.	Check the pump contactor switch.	If it is broken, change it with a new one.
Motor might be broken.	Check the related motor.	If the motor is broken change it with a new one.
Cable that connects the motor to the panel might be broken.	Check the related cable.	If the cable is broken, change it with a new one.

Fuses inside the panel go off.

POSSIBLE REASON	FAULT DETECTION	SOLUTION
There might be connected motor or equipment to panel more than capacity of the panel.	Check the equipment and motor numbers connected to panel.	Disconnect the equipment connected to the panel that are not declared by VKS for the related panel.
Charge unit might be broken.	Check the charge unit.	If the charge unit is broken, change it with a new one.
One of the fan or pump contactor switches might be broken.	Check all the contactor switches.	If there is a broken contactor switch inside panel, change it with new one.
Fuse might be broken. NOTE: This situation has never been observed before.	Check the fuse.	If it is broken change it with a new one.

VKS CHICKBOOK microcontroller is not working.

POSSIBLE REASON	FAULT DETECTION	SOLUTION
The connectors of VKS CHICKBOOK might be loose.	Check the sockets of VKS CHICKBOOK microcontroller.	If there is a loose socket, tighten it and solve the problem.
VKS CHICKBOOK might be broken.	If you tried to solve your problem with all ways explained above but you could not solve your problem, this means that your VKS CHICKBOOK microcontroller is broken.	Please refer to your seller.